

Unit Dimensions

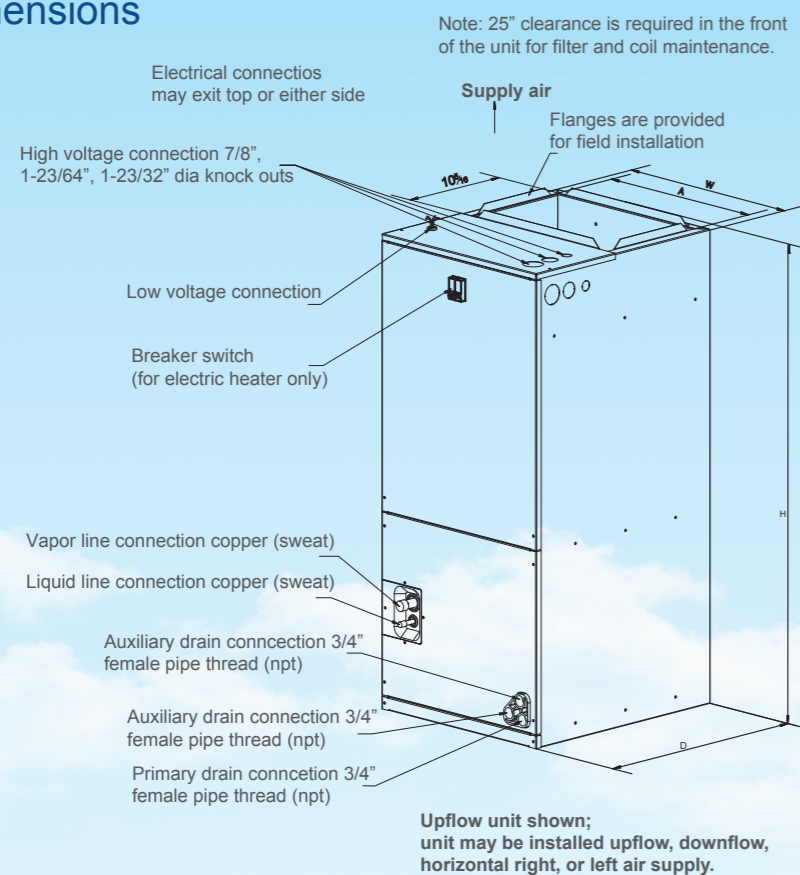

R410A Air Handler Dimensional Data

Model data	Unit Height "H" IN. [mm]	Unit Width "W" IN. [mm]	Unit Length "D" IN. [mm]	Supply Duct "A"	Unit Weight /Shipping Weight (LBS./kg)
18	41-3/8"[1050]	18-1/8"[460]	20-1/2"[520]	16"[406]	106/119 [48]/[54]
24	41-3/8"[1050]	18-1/8"[460]	20-1/2"[520]	16"[406]	106/119 [48]/[54]
30	41-3/8"[1050]	18-1/8"[460]	20-1/2"[520]	16"[406]	119/132 [54]/[60]
36	46-1/2"[1180]	19-5/8"[500]	21-5/8"[550]	18"[456]	141/156 [64]/[71]
42	46-1/2"[1180]	19-5/8"[500]	21-5/8"[550]	18"[456]	141/156 [64]/[71]
48	54-1/2"[1385]	22"[560]	24"[610]	19-1/2"[496]	172/187 [78]/[85]
60	54-1/2"[1385]	22"[560]	24"[610]	19-1/2"[496]	172/187 [78]/[85]



GD Midea Heating & Ventilating Equipment Co., Ltd.
Is certified under the ISO 9001 International standard for quality assurance.
NO.01 100 019209



GD Midea Heating & Ventilating Equipment Co., Ltd.
Is certified under the ISO 14001 International standard for environmental management.
Certificate No. 15912E10020R0L

Commercial Air Conditioner Business Units Midea Group

Add: West region of Midea commercial air conditioner department, Industry Avenue, Beijiao, Shunde, Foshan, Guangdong, P.R. China Postal code: 528311

Tel: +86-757-22390820 Fax: +86-757-23270470

<http://global.midea.com.cn>

<http://www.midea.com>

Note: The data in this book may be changed without notice for further improvement on quality and performance.

Dealer information



Commercial Air conditioner

13 SEER air handler

- **Anti-rust:** painted galvanized steel cabinet, 500 hours' salt spray test
- **Low noise:** Fully insulated design helps to minimize indoor noise level
- **Common maintaining:** Removing the front panel will allow the blower assembly and coil assembly slide-out easily
- **Filter rack:** filter rack at the bottom, very convenient for installation.
- **Multi-position:** 4-way convertible design for upflow, downflow, horizontal left and horizontal
- **right. Motor:** quiet operation 3-speed PSC motor



13 SEER Wall mounted Air handler

- Suitable for use with R410A and R22 refrigerants
- Match with cooling only or heat pump operation
- Multi-speed PSC motor
- AHRI Listed & ETL Certified
- Accessories
- Electric heater: 5kW/7.5kW/10kW

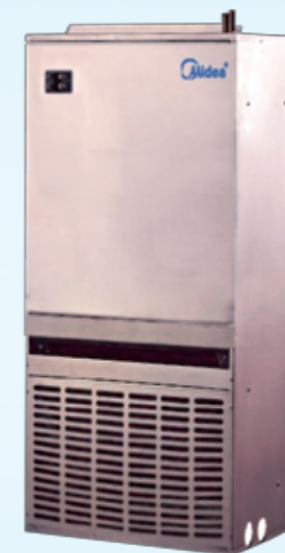

Specifications - R410A Air handler

Sale Model		MVC-18WN1-M13	MVA-24HWN1-M13	MVC-30WN1-M13	MVC-36WN1-M13	
Power supply	V-Ph-Hz	208/230V 1Ph 60Hz	208/230V 1Ph 60Hz	208/230V 1Ph 60Hz	208/230V 1Ph 60Hz	
MCA	AMPS	0.9	1.3	1.9	2.2	
MOP	AMPS	15	15	15	15	
MOTOR	Model	YDK100-6F	YDK135-6F	YDK180-6F	YDK220-6F	
	Type	PSC	PSC	PSC	PSC	
	Capacitor	uF	6	6	10	
	Rated HP		1/8	0.2	1/4	
	Rated RPM	r/min	1075	1075	1075	
Indoor fan	material	Metal	Metal	Metal	Metal	
	Type	Fan impeller	Fan impeller	Fan impeller	Fan impeller	
	Diameter	inch	10-5/8	10-5/8	10-5/8	
	Height	inch	8-1/8	8-1/8	10-3/4	
In door coil type		Copper tube and Aluminum fin				
Indoor limit value of static pressure and air flow	Pa/CFM	25/622	25/802	40/992	40/1389	
Indoor sound level (sound pressure level)	dB(A)	42/39/35	49/46/40	48/47/45	47/46/44	
Indoor unit	Dimension (W*H*D)	inch	18-1/8x41-3/8x20-1/2	18-1/8x41-3/8x20-1/2	18-1/8x41-3/8x20-1/2	19-5/8x46-1/2x21-5/8
	Packing (W*H*D)	inch	21x42-7/10x24-1/6	21x42-7/10x24-1/6	21x42-7/10x24-1/6	22-3/5x47-4/5x25-7/20
	Net/Gross weight	lbs	106/117	114/128	115/126	135/146
throttle type		Orifice	Orifice	Orifice	Orifice	
Refrigerant connection valve size	Liquid side/ Gas side	inch	3/8 / 3/4	3/8 / 3/4	3/8 / 3/4	
Shipping per STD40HQ		210	210	210	154	

Ultimate data changing right reserved by manufacturer.

Sale Model		MVC-42WN1-M13	MVC-48WN1-M13	MVA-60HWN1-M13	
Power supply	V-Ph-Hz	208/230V 1Ph 60Hz	208/230V 1Ph 60Hz	208/230V 1Ph 60Hz	
MCA	AMPS	2.3	2.8	3.5	
MOP	AMPS	15	15	15	
MOTOR	Model	YDK270-6F	YDK300-6F	YDK400-6F	
	Type	PSC	PSC	PSC	
	Capacitor	uF	10	20	
	Rated HP		1/2	1/2	
	Rated RPM	r/min	1075	1075	
Indoor fan	material	Metal	Metal	Metal	
	Type	Fan impeller	Fan impeller	Fan impeller	
	Diameter	inch	10-5/8	10-5/8	
	Height	inch	10-3/4	10-3/4	
In door coil type		Copper tube and Aluminum fin			
Indoor limit value of static pressure and air flow	Pa/CFM	40/1389	50/1595	50/1966	
Indoor sound level (sound pressure level)	dB(A)	51/50/47	54/52/49	50/49/47	
Indoor unit	Dimension (W*H*D)	inch	19-5/8x46-1/2x21-5/8	22x54-1/2x24	22x54-1/2x24
	Packing (W*H*D)	inch	22-3/5x47-4/5x25-7/20	25x55-4/5x27-7/10	25x55-4/5x27-7/10
	Net/Gross weight	lbs	135/146	170/185	172/187
throttle type		Orifice	Orifice	Orifice	
Refrigerant connection valve size	Liquid side/ Gas side	inch	3/8 / 3/4	3/8 / 7/8	
Shipping per STD40HQ		154	104	104	

Ultimate data changing right reserved by manufacturer.

Specifications - R410A Wall mounted

Sale Model		MVB-18WN1-M13	MVB-24WN1-M13	MVB-30WN1-M13	MVB-36WN1-M13	
Power supply	V-Ph-Hz	208/230V 1Ph 60Hz	208/230V 1Ph 60Hz	208/230V 1Ph 60Hz	208/230V 1Ph 60Hz	
MCA	AMPS	1	1.3	1.6	2.3	
MOP	AMPS	15	15	15	15	
MOTOR	Model	YDK100-6Q	YDK165-6Q	YDK220-6F	YDK270-6F	
	Type	PSC	PSC	PSC	PSC	
	Capacitor	uF	6	6	15	
	Rated HP		0.17	0.25	0.33	
	Rated RPM	r/min	1075	1075	1075	
Indoor fan	material	Metal	Metal	Metal	Metal	
	Type	Fan impeller	Fan impeller	Fan impeller	Fan impeller	
	Diameter	inch	10-3/4	10-3/4	10-3/4	
	Height	inch	6	6	8	
In door coil type		Coppertube and Aluminum fin				
Indoor limit value of static pressure and air flow	Pa/CFM	25/650	25/850	25/1127	25/1213	
Indoor sound level (sound pressure level)	dB(A)	50	54	53	54	
Indoor unit	Dimension (W*H*D)	inch	20-1/2x36-1/2x15	20-1/2x36-1/2x15	22x39-1/2x19	22x39-1/2x19
	Packing (W*H*D)	inch	23-1/5x40-1/4x18-1/2	23-1/5x40-1/4x18-1/2	24-4/5x42-1/3x21-4/5	24-4/5x42-1/3x21-4/5
	Net/Gross weight	lbs	88/99	88/99	110/121	110/121
throttle type		Orifice	Orifice	Orifice	Orifice	
Refrigerant connection valve size	Liquid side/ Gas side	inch	3/8 / 3/4	3/8 / 3/4	3/8 / 3/4	
Shipping per STD40HQ		258	258	176	176	

Ultimate data changing right reserved by manufacturer.

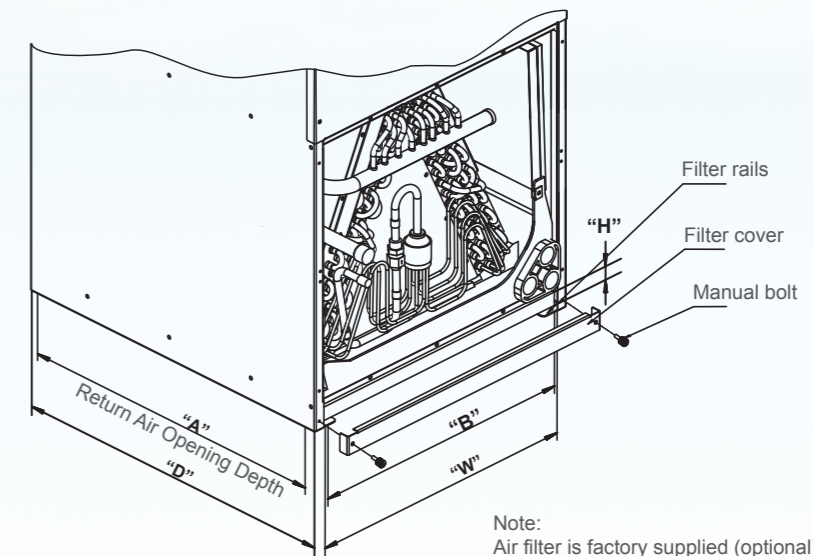

R410A Air Handler Dimensional Data

Model	Filter Size IN [mm]	"W" IN [mm]	"D" IN [mm]	"H" IN [mm]	Return Width "A" IN	Return Length "B" IN
18/24/30	16X20[406X508]	16.8[426]	20.4[518]	1[25.4]	19.6	14.8
36/42	18X20[457X508]	18.3[466]	21.6[548]	1[25.4]	20.8	16.3
48/60	20X22[508X559]	20.7[526]	23.9[608]	1[25.4]	23	18.8

Filter Installation Dimensions

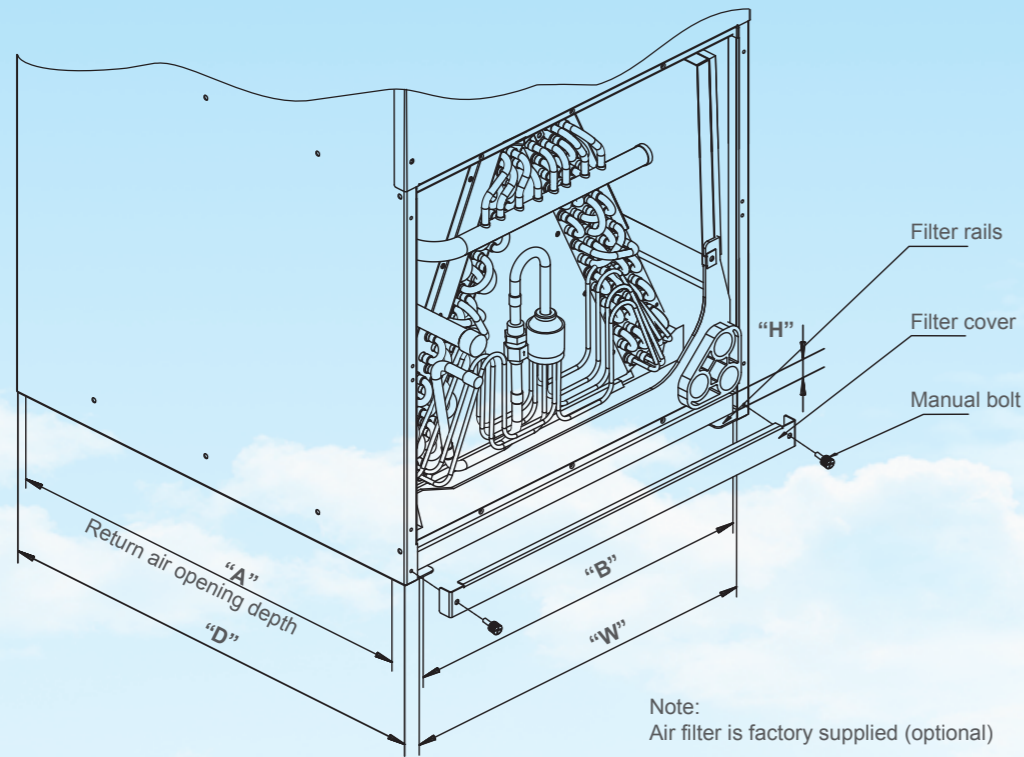

Dimensional Data

Model	Filter Size IN [mm]	"W" IN [mm]	"D" IN [mm]	"H" IN [mm]	Return Width "A" IN	Return Length "B" IN
18	16X20[406X508]	16.8[426]	20.4[518]	1[25.4]	19.6	14.8
24B/30B/36	18X20[457X508]	18.3[466]	21.6[548]	1[25.4]	20.8	16.3
42C/48/60	20X22[508X559]	20.7[526]	23.9[608]	1[25.4]	23	18.8



GD Midea Heating & Ventilating Equipment Co., Ltd.
Is certified under the ISO 9001 International standard for quality assurance.
NO.01 100 019209



GD Midea Heating & Ventilating Equipment Co., Ltd.
Is certified under the ISO 14001 International standard for environmental management.
Certificate No.15912E10020R0L

Commercial Air Conditioner Business Units Midea Group

Add: West region of Midea commercial air conditioner department, Industry Avenue, Beijiao, Shunde, Foshan, Guangdong, P.R.China Postal code: 528311

Tel: +86-757-22390820 Fax: +86-757-23270470

<http://global.midea.com.cn>

<http://www.midea.com>

Note: The data in this book may be changed without notice for further improvement on quality and performance.



Commercial Air conditioner

14 SEER air handler

- **Anti-rust:** painted galvanized steel cabinet, 500 hours' salt spray test
- **Low noise:** Fully insulated design helps to minimize indoor noise level
- **Common maintaining:** Removing the front panel will allow the blower assembly and coil assembly slide-out easily
- **Filter rack:** filter rack at the bottom, very convenient for installation
- **Multi-position:** 4-way convertible design for upflow, downflow, horizontal left and horizontal right.
- **Motor:** quiet operation 3-speed PSC motor
AHRI Listed & ETL Certified
Accessories
- **Electric heater:**
5kW/7.5kW/10kW/15kW/20kW



Dealer information



Specifications - R410A Air Handler

Sale Model		MVA-18HWN1-M13	MVA-24N1B	MVA-30N1B	MVA-36HWN1-M13	
Powersupply	V-Ph-Hz	208/230V 1Ph	208/230V 1Ph 60Hz	208/230V 1Ph 60Hz	208/230V 1Ph 60Hz	
MCA	AMPS	0.9	1.3	1.9	2.3	
MOP	AMPS	15	15	15	15	
MOTOR	Model	YDK100-6F	YDK135-6F	YDK150-6F	YDK270-6F	
	Type	PSC	PSC	PSC	PSC	
	Capacitor	uF	6	6	10	
	Rated HP		1/8	0.2	0.25	
	Rated RPM	r/min	1075	1075	1075	
Indoor fan	material	Metal	Metal	Metal	Metal	
	Type	Fan impeller	Fan impeller	Fan impeller	Fan impeller	
	Diameter	inch	10-5/8	10-5/8	10-5/8	
	Height	inch	8-1/8	10-3/4	10-3/4	
In door coil type		Coppertube and Aluminum fin				
Indoor limit value of static pressure and air flow		25/622	25/962	40/1127	40/1389	
Indoor sound level (sound pressure level)	dB(A)	45/42/38	48/47/42	50/48/44	50/48/44	
Indoor unit	Dimension (W×H×D)	inch	18-1/8x41-3/8x20-1/2	19-5/8x46-1/2x21-5/8	19-5/8x46-1/2x21-5/8	19-5/8x46-1/2x21-5/8
	Packing (W×H×D)	inch	21x42-7/10x24-1/6	22-3/5x47-4/5x25-7/10	22-3/5x47-4/5x25-7/10	22-3/5x47-4/5x25-7/10
	Net/Gross weight	lbs	114/128	136/152	136/152	141/156
throttle type		TXV	Orifice	Orifice	TXV	
Refrigerant connection valve size	Liquid side/ Gas side	inch	3/8 / 3/4	3/8 / 3/4	3/8 / 3/4	3/8 / 3/4
Shipping per STD40HQ		210	154	154	154	

Ultimate data changing right reserved by manufacturer.

Sale Model		MVA-42N1C	MVA-48HWN1-M13	MVA-60HWN1-M13	
Power supply	V-Ph-Hz	208/230V 1Ph 60Hz	208/230V 1Ph 60Hz	208/230V 1Ph 60Hz	
MCA	AMPS	2.3	2.8	3.5	
MOP	AMPS	15	15	15	
MOTOR	Model	YDK270-6F	YDK300-6F	YDK400-6F	
	Type	PSC	PSC	PSC	
	Capacitor	uF	10	20	
	Rated HP		0.5	0.5	
	Rated RPM	r/min	1075	1075	
Indoor fan	material	Metal	Metal	Metal	
	Type	Fan impeller	Fan impeller	Fan impeller	
	Diameter	inch	10-5/8	10-5/8	
	Height	inch	10-3/4	10-3/4	
In door coil type		Copper tube and Aluminum fin			
Indoor limit value of static pressure and air flow	Pa/CFM	40/1509	50/1595	50/1966	
Indoor sound level (sound pressure level)	dB(A)	51/50/47	54/52/49	54/52/49	
Indoor unit	Dimension (W×H×D)	inch	22x54-1/2x24	22x54-1/2x24	22x54-1/2x24
	Packing (W×H×D)	inch	25x55-4/5x27-7/10x55-4/5	25x55-4/5x27-7/10x55-4/5	25x55-4/5x27-7/10x55-4/5
	Net/Gross weight	lbs	172/187	172/187	172/187
throttle type		Orifice	TXV	Orifice/TXV	
Refrigerant connection valve size	Liquid side/ Gas side	inch	3/8 / 3/4	3/8 / 7/8	3/8 / 7/8
Shipping per STD40HQ		104	104	104	

Ultimate data changing right reserved by manufacturer.

Unit Dimensions

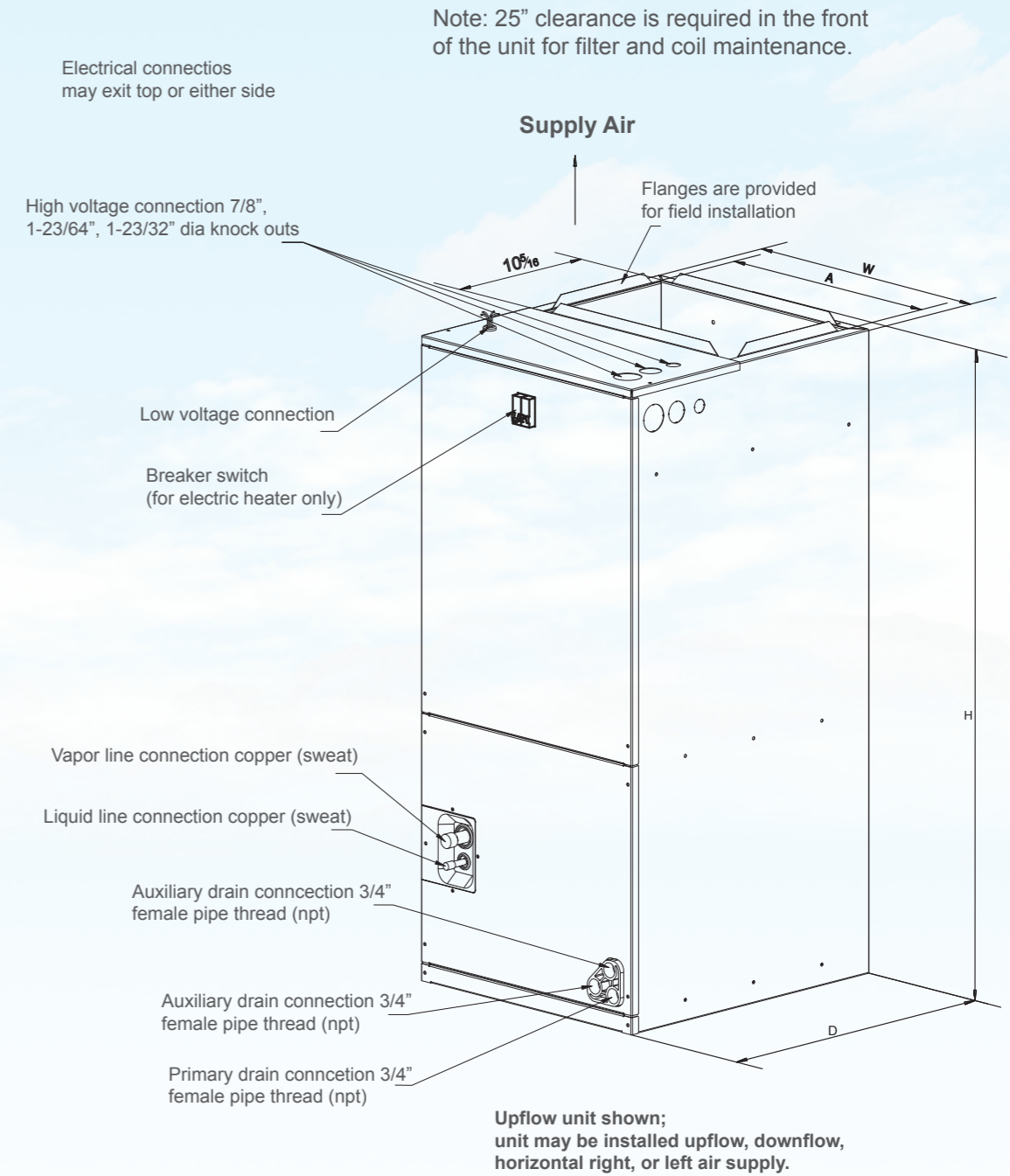

Dimensional Data

Model	Filter Size IN [mm]	"W" IN [mm]	"D" IN [mm]	"H" IN [mm]	Return width "A" IN	Return Length "B" IN
18	16X20[406X508]	16.8[426]	20.4[518]	1[25.4]	19.6	14.8
24B/30B/36	18X20[457X508]	18.3[466]	21.6[548]	1[25.4]	20.8	16.3
42C/48/60	20X22[508X559]	20.7[526]	23.9[608]	1[25.4]	23	18.8